

Instruction Manual

Components

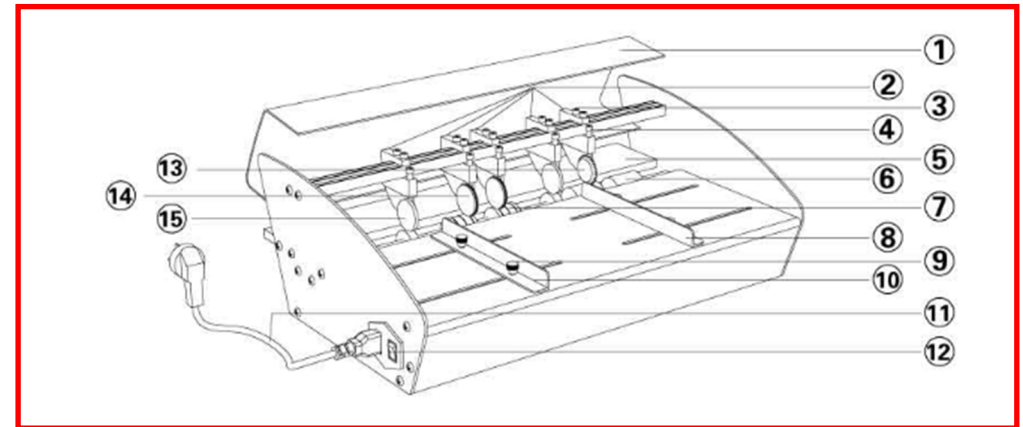

For additional parts, contact

www.galaxyprintfinishing.com

Phone: +44(0)1618832722

The Print Finishing specialist

- | | | | |
|---|--------------------------|---|----------------------------|
| ① | Cover | ⑨ | Adjusting screw |
| ② | Tool rest | ⑩ | Left paper positioning |
| ③ | Head screw | ⑪ | Power line |
| ④ | Pressure adjusting screw | ⑫ | Power switch |
| ⑤ | Paper platform | ⑬ | Perforate wheel (optional) |
| ⑥ | Bottom wheel | ⑭ | Creasing wheel |
| ⑦ | Rolling groove wheel | ⑮ | Paper press wheel |
| ⑧ | Right paper positioning | | |

1. Remove the machine from the box and place on a flat surface.

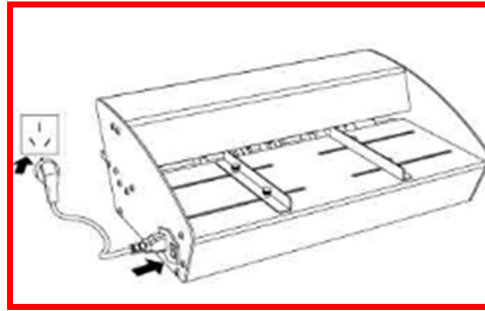

2. Adjust the creasing position and the indentation / depth according to your needs, the upper indent should align with the centre of the crease.

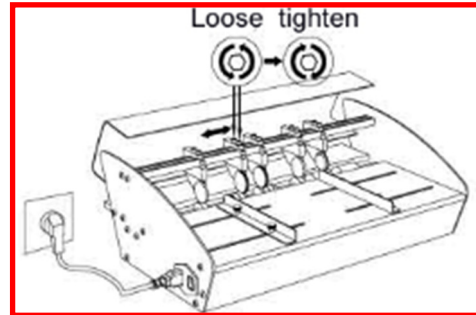

3. Adjust paper position accordingly.

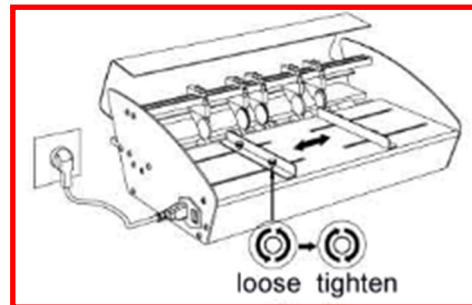

4. Insert paper/card and adjust the creasing pressure as well as feeding pressure on the paper feeding wheels

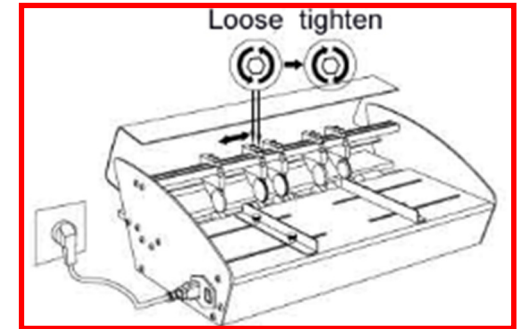

5. Caution when using the machine, always make sure the safety lid is closed and always make sure to switch off the machine when not in use or when changing or moving the blades.

Specification

Creasing wheel	4
Feeding wheel	2
Perforating wheel	1 (optional)
Dimension	510x325x172mm
N.G	9.9kg
POWER	220V-240V 50HZ-60HZ